

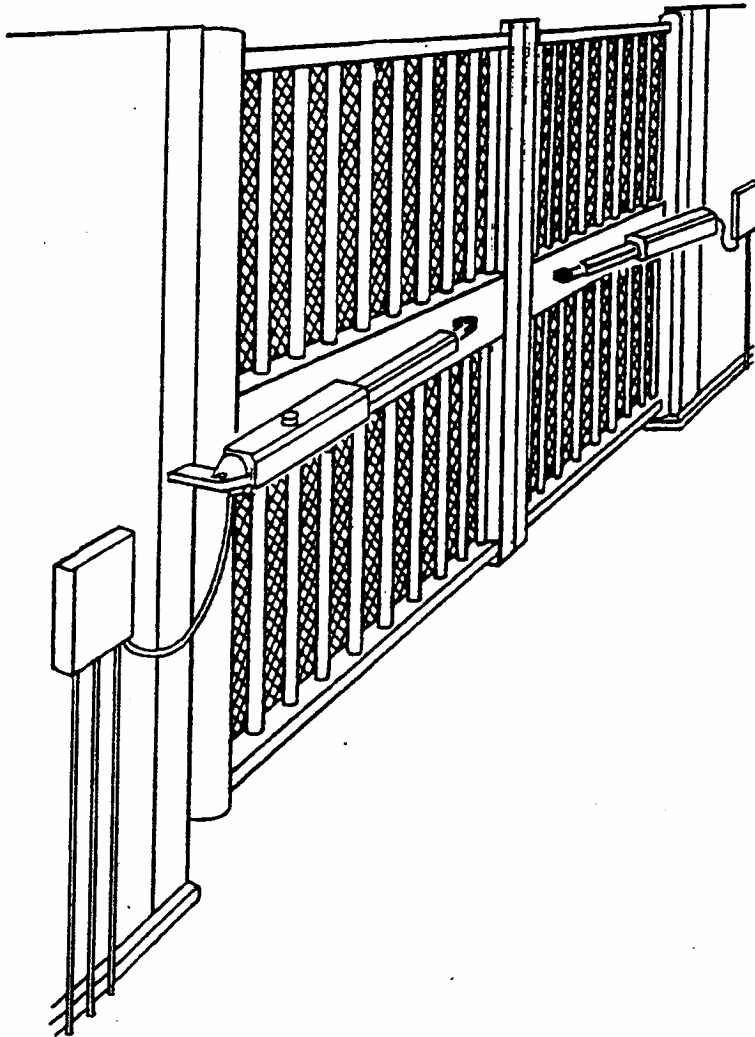

## Installation and Maintenance Manual



### **Commercial Hydraulic Vehicular Swing Gate Operator MODEL HL410 and F4PLUS**

The Upswung HL410 Hydraulic Opener and 4 PLUS electronic control unit for automation of opener(s) for swing gates. It offers a complete operating range (multi-user, step-by-step, step-by-step with automatic reclosing, pedestrian gate, and Power Boost ) and adjustment functions (run time, pause time, phase shift and motor power). It is versatile because of its options (4 limit switches, pre-flashing, flashing light controlled by control unit, courtesy light, cut-out of unused inputs with dip switches, built-in or plug-in radio).

Easy to install with control LEDs, the extractable terminal boards and the silk-screen printing on the printed circuit indicating connections and functions.

Upswung LLC declines all responsibility for any inaccuracies contained in this manual and reserves the right to make modifications – without prior notice.

# Swing Gate Operator Model HL410

## Table of Contents

DESCRIPTION	PAGE
Specifications & Capacities .....	3
Safety Information .....	4
Wiring Information .....	5
Mechanical Gate Stops .....	6
Gate Brackets .....	6
Optional Mounting Styles .....	7
Outward Swing Information .....	7
Operator Mounting .....	8
Control Panel Mounting .....	8
Primary Voltage Wiring .....	9
Control Wiring .....	10
Control Panel Adjustments.....	11
Final checks and Testing.....	11,12
Control Panel Layout.....	13
Troubleshooting.....	14
Hydraulic Adjustments.....	15
Rod Cover .....	16
Operator Check-out .....	16
Warranty Information ..	17
Parts Identification .....	17
Maintenance Schedule .....	18

## Parts & Components

Inspect the operator for possible shipping damage or shortage of parts. Check all accessories as listed below. These do not include any accessories that were ordered separately.

DESCRIPTION	QUANTITY
Model HL410 Drive Unit	1
Front Mounting Bracket	1
Rear Mounting Bracket	1
Rod Cover	1
Rear Mounting Pin	1
Front Pin	1
Disconnect Key	1
Gate Caution Plate	2
Troubleshooting Guide	1
Controller ( may be sold separately)	1

- Gate Caution Plates are to be installed on the gate in a position where they can be easily seen.
  - CE listings are valid only if a Upswung LLC drive unit is used with a Upswung LLC controller.

+ Packed with controller

## Specifications & Capacities

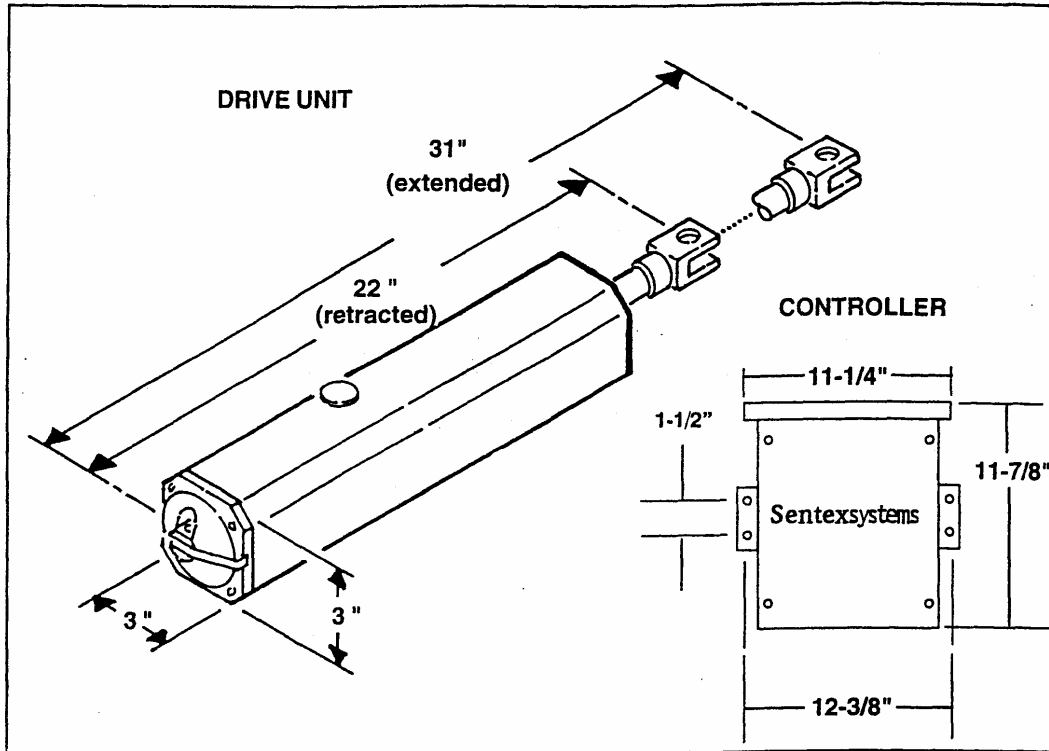

### Maximum Length VS. Maximum Weight

0 to 8 ft	500 lbs
8 to 10ft	300 lbs
10 to 12 ft	250 lbs

The Model HL410-11 is a light duty commercial gate operator designed to operate a typical swing gate. Because operating requirements and gate construction vary by installation, the capacities shown should be used as a guide to determine the expected performance of the unit. Contact an Upswung LLC dealer if your application exceeds any of the recommended limits to determine the proper unit needed.

#### Double Check Operator Capacities!

Do not use this operator on "walk or pedestrian" gates. Do Not Misapply Product for other uses. Warranty will be void!

\*Please note that hydraulic locking is not intended to be a replacement for security type locks. External lock systems should be used if:

- a. High security is required for the installation.
- b. The length of the gate exceeds 12 feet.
- c. The gate has a large surface area.
- d. The installation area could have strong or gusty winds.

### Specifications

Cycles per hour (Full open & close) 10 maximum  
 Time to open (Avg.) 20 seconds  
 Close Direction  
 Hydraulic (gate) Locking\*  
 Primary Voltage 120 VAC - 60 HZ  
 Secondary Voltage 24 VAC  
 Power Consumption 335 W (full load)  
 Current 3-1/2 A (full load)  
 Motor R.P.M. 1700  
 Motor Overload 1 350C  
 Fluid Dexron ATF

\*It is highly recommended that you reconsider using this type of gate operator on any solid faced gate, without an external lock system on both the open and closed position. Strong winds will greatly affect the efficiency of this operator on these types of gates.

#### Important

The gate must be level and operate smoothly and freely. If it does not, damage to the operator may result and the life expectancy will be greatly reduced.



## Safety Information



Automatic gate operators provide convenience and security to their users. However, because these machines can produce high levels of force, it is important that all installers and users be aware of the potential hazards associated with improperly installed or adjusted units. The information on this page contains various safety precautions and warnings, some highlighted with this symbol. This symbol will identify conditions that can result in serious injury or death. Take time to read and follow these precautions and the other information provided.

**NOTE:** This operator is intended to be apart of a total gate operating system. It is the responsibility of the purchaser and Installer to ensure that the total system is safe for its intended use.

**⚠ PLEASE INSTALL ALL SAFETY DEVICES NECESSARY TO MAKE THIS INSTALLATION AS SAFE AS POSSIBLE.**

<p><b>Before Installation:</b></p> <ol style="list-style-type: none"> <li>1. Check to see that this is the proper operator for this application. (See page 3)</li> <li>2. Ensure that the gate has been properly installed and works freely in both directions. Repair or service any worn or damaged gate hardware.</li> <li>⚠ 3. Install the gate operator on the inside of the property and/or fence line. Do not install an operator on the public side of the gate.</li> <li>4. If the gate is near a residential area, or pedestrian traffic is expected near the gate, additional safety equipment such as electric gate edges or photocell detectors must be installed to prevent entrapment. Severe injury or death can result from entrapment with the gate.</li> <li>⚠ 5. Certain types of gates can create greater hazards to pedestrians. Any gate that has exposed, reachable pinch points or is constructed to allow arms and legs to pass through it is a potential hazard. These hazards should be guarded against.</li> <li>⚠ 6. Review the operation of the unit and become familiar with the manual disconnect system and safety features of the unit.</li> <li>⚠ 7. Outdoor or easily accessed controls should be of the security type to prohibit unauthorized use of the gate.</li> </ol> <p><b>During Installation:</b></p> <ol style="list-style-type: none"> <li>1. Be aware of all moving parts and avoid close proximity to any pinch points.</li> <li>2. Disconnect power at the service panel before making any high voltage power connections.</li> </ol>	<p><b>During Installation:</b></p> <ol style="list-style-type: none"> <li>⚠ 3. Place controls far enough from the gate so that a user can see but cannot touch the gate while operating the controls.</li> <li>4. Place warning signs provided on the gate or in a high visibility area to alert of automatic gate operation.</li> </ol> <p><b>After Installation:</b></p> <ol style="list-style-type: none"> <li>1. Make sure the user understands the basic function Safety features of the systems.</li> <li>2. Leave this manual and the troubleshooting guide with the end user.</li> </ol> <p><b>End User:</b></p> <ol style="list-style-type: none"> <li>⚠ 1. Periodically check all safety systems. If these functions are observed to operate improperly, discontinue use and contact a professional for service immediately.</li> <li>2. Follow recommended maintenance schedule.</li> <li>⚠ 3. Do not allow children to play on or near the gate operating system.</li> <li>⚠ 4. Never operate gate until you have it in full sight.</li> <li>5. See page 12 for pressure valves and manual disconnect information.</li> </ol>
--	---

## General Wiring Information

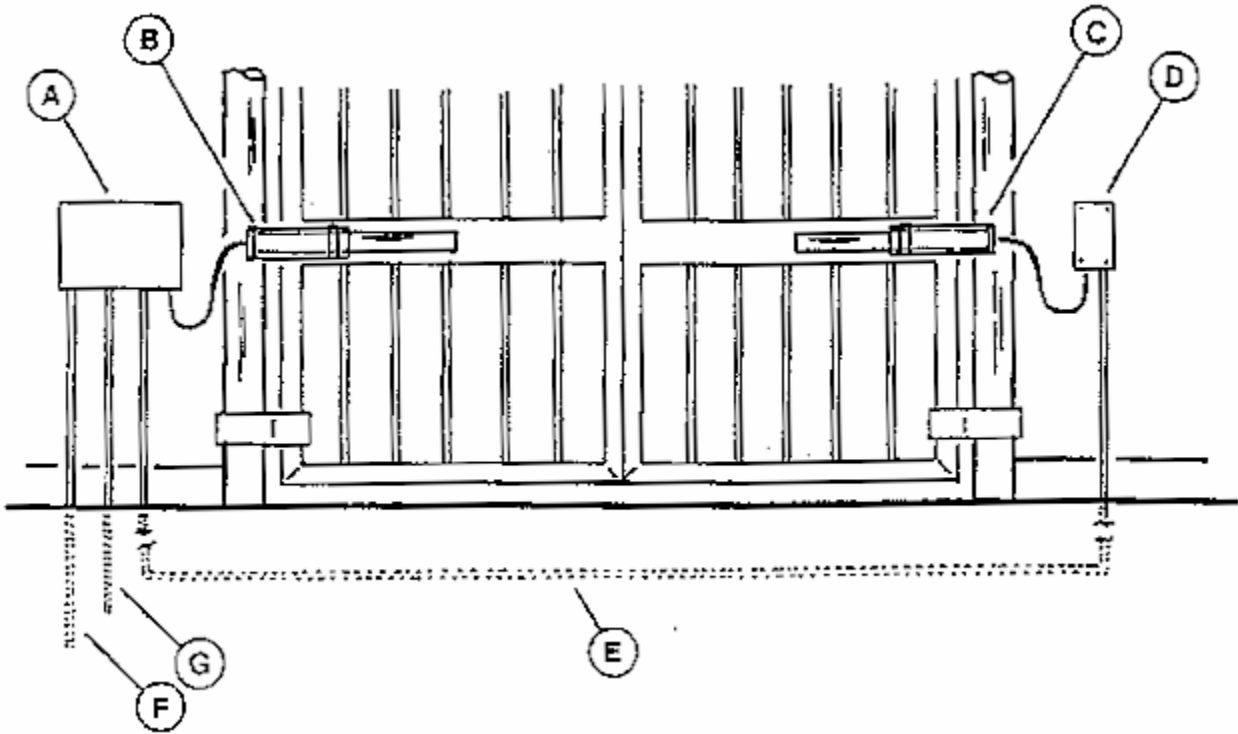

- |  |  |
|--|--|
| <p><b>A - Controller</b><br/> <b>B- Drive Unit</b><br/> <b>C- Drive Unit, Slave Option</b><br/> <b>D- Junction Box, Slave Option</b></p> | <p><b>E- Conduit for Slave (4 wires)</b><br/>         Suggest-10 gauge stranded wire<br/> <b>F- Conduit, Power (3 wires)</b><br/> <b>G- Conduit, Control (as required)</b></p> |
|--|--|

NOTE: Other wire runs may be required, depending on your application.

### Wiring Information

The distance shown on charts is the total length of wire, measured in feet from the control panel to the power source. Do not exceed maximum distance.

<ol style="list-style-type: none"> <li>1. Supply voltage must be within 10% of the unit's rating under load conditions. (Measure voltage at the unit.)</li> <li>2. Connect power in accordance with local codes.</li> <li>3. Wire tables are based on stranded copper wire. Wire insulation must be suitable to application.</li> <li>4. All units', single and master/slave, must be properly grounded with a supply grounding conductor.</li> <li>5. Do not run control wires in the same conduit with power wires.</li> <li>6. Do not use solid copper wires for controls.</li> </ol>	<p><b>Power Wiring</b></p> <table border="1" style="width: 100%; border-collapse: collapse;"> <thead> <tr> <th colspan="2" style="text-align: center;"><u>Maximum Distance</u></th> <th style="text-align: center;"><u>Wire Gauge</u></th> </tr> <tr> <th style="text-align: left;">Single unit</th> <th style="text-align: left;">Dual unit</th> <th></th> </tr> </thead> <tbody> <tr> <td>200ft</td> <td>100ft</td> <td style="text-align: center;">10</td> </tr> <tr> <td>310 ft</td> <td>155ft</td> <td style="text-align: center;">8</td> </tr> <tr> <td>500ft</td> <td>250 ft</td> <td style="text-align: center;">6</td> </tr> </tbody> </table>	<u>Maximum Distance</u>		<u>Wire Gauge</u>	Single unit	Dual unit		200ft	100ft	10	310 ft	155ft	8	500ft	250 ft	6
	<u>Maximum Distance</u>		<u>Wire Gauge</u>													
	Single unit	Dual unit														
	200ft	100ft	10													
	310 ft	155ft	8													
	500ft	250 ft	6													
<p><b><u>Control Wiring</u></b></p> <table border="1" style="width: 100%; border-collapse: collapse;"> <tbody> <tr> <td style="width: 50%;">200ft</td> <td style="width: 50%; text-align: center;">18</td> </tr> <tr> <td>400ft</td> <td style="text-align: center;">16</td> </tr> </tbody> </table>	200ft	18	400ft	16												
200ft	18															
400ft	16															
<p>Do not use parallel conductor cable.</p>																
<p>If PVC type conduit is used in a single trench, allow a minimum of six (6) inches between lines.</p>																

## Step 1: Gate Stops

The gate must have a permanent gate stop at the full closed position. It is also highly recommended that there be a gate stop at the determined full open position. These are to prevent the piston from bottoming in the cylinder and prolong the unit's life.

## Step 2: Gate Brackets

Locate the positions of the front and rear mounting brackets. It is recommended that these brackets be positioned at the midpoint between the gate hinges.

Dimension A  
26 inches  
27 inches

Gate Opening  
90 degrees only  
90 or 100 degrees only

It is very important that they be in-line with each other! The operator must be close to level.

The two brackets should be welded to the gate and the post as shown. They can be welded directly or modified to suit your particular application.

**NOTE:**  
Slight modifications to the dimensions shown below can be made to modify the degree of opening and the speed of the unit.

Do not weld brackets with operator attached. Avoid getting weld splatter on the piston rod. Keep piston rod clean and smooth. Avoid nicks.

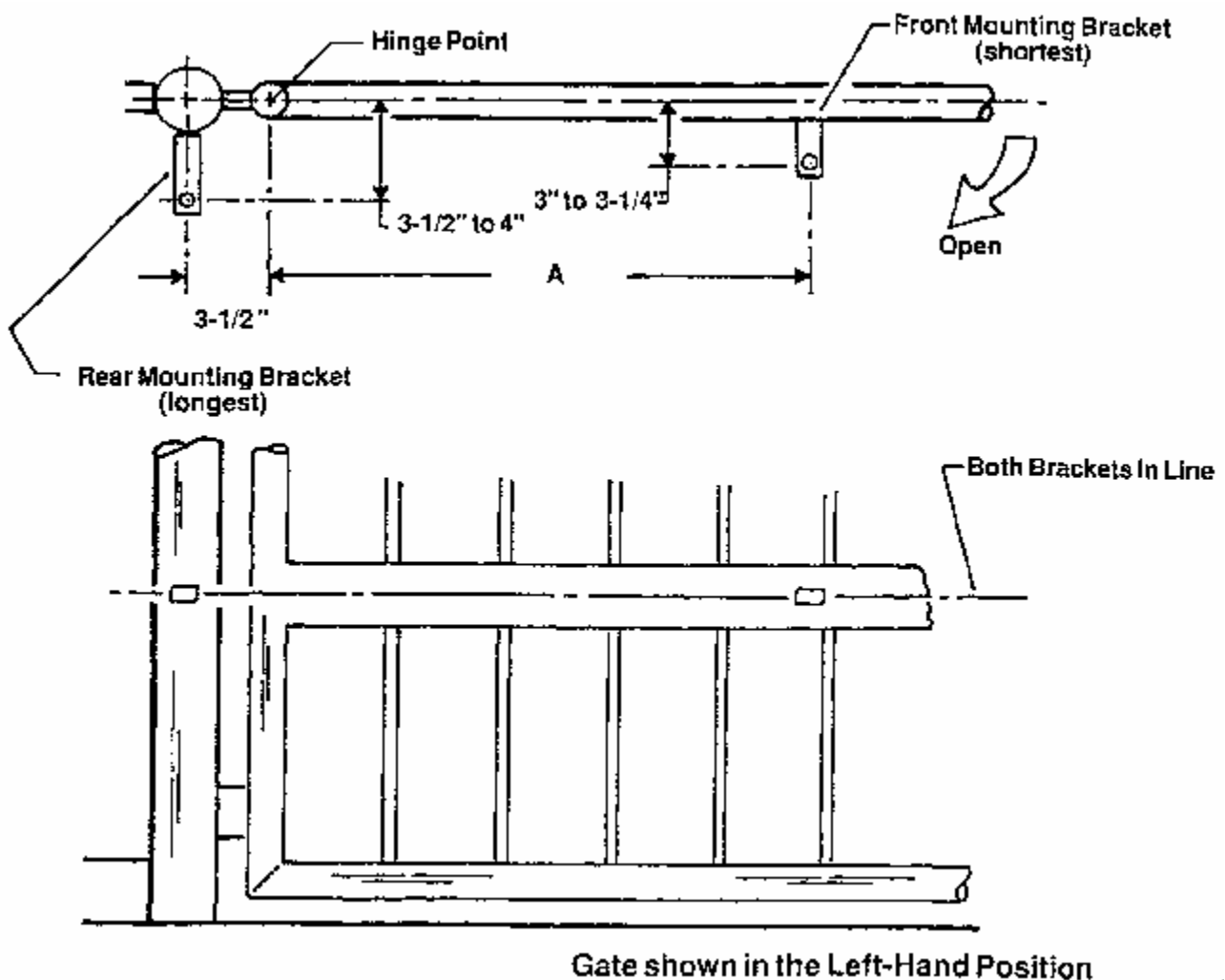

## Step 3: Optional Mounting

Do not install outward swing gates in applications where gates will swing into a public area. Serious injury could result from someone being hit by the gate. Use outward swing gates only in applications where the gate will open into a secure area and where the person operating the gate has control of traffic in the path of the gate.



Do not use the "Open Only" mode of the controller for an outward swing gate installation.

- A. Gate stops must be used at both the full open and close positions. (See Step 1)
- B. Follow Step 2 for mounting of gate brackets. The difference being that the rear mounting point is 3-1/2" to 4" to the right of the hinge point instead of 3-1/2" to 4" to the left as shown in step 2. (The distance between the mounting points is 16-1/2" instead of 25 1/2").
- C. The piston rod should be fully retracted when the gate is in the closed position. The unit should be mounted with the gate in the closed position. (See Step 4)
- D. Proceed to Step 5. Follow wiring for outward swing.

### Large Pillars or Walls

If the dimension from the centerline of the gate to the outer edge of the pillar or wall is 3-3/4" or less, you can notch out part of the pillar or wall (figure A), as shown. If this dimension is larger than 3-3/4", then it will be necessary to notch out a larger portion (figure B), large enough to house the unit. The notch should be 5" to 8" high. Contact a Upswung dealer if your application does not fit these guidelines.

#### Optional Mounting – notch as required

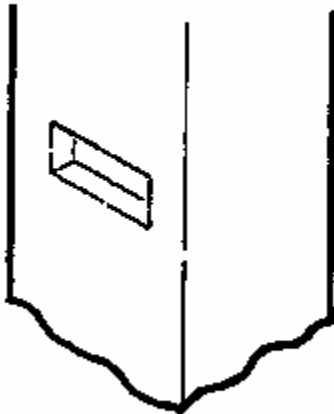

Figure A

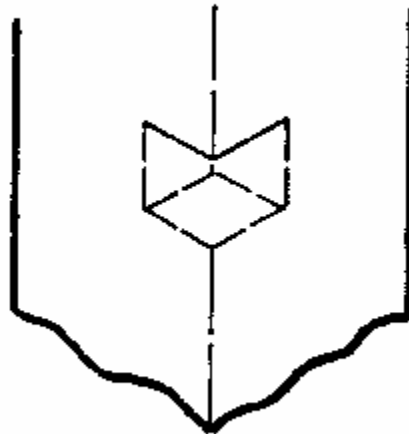
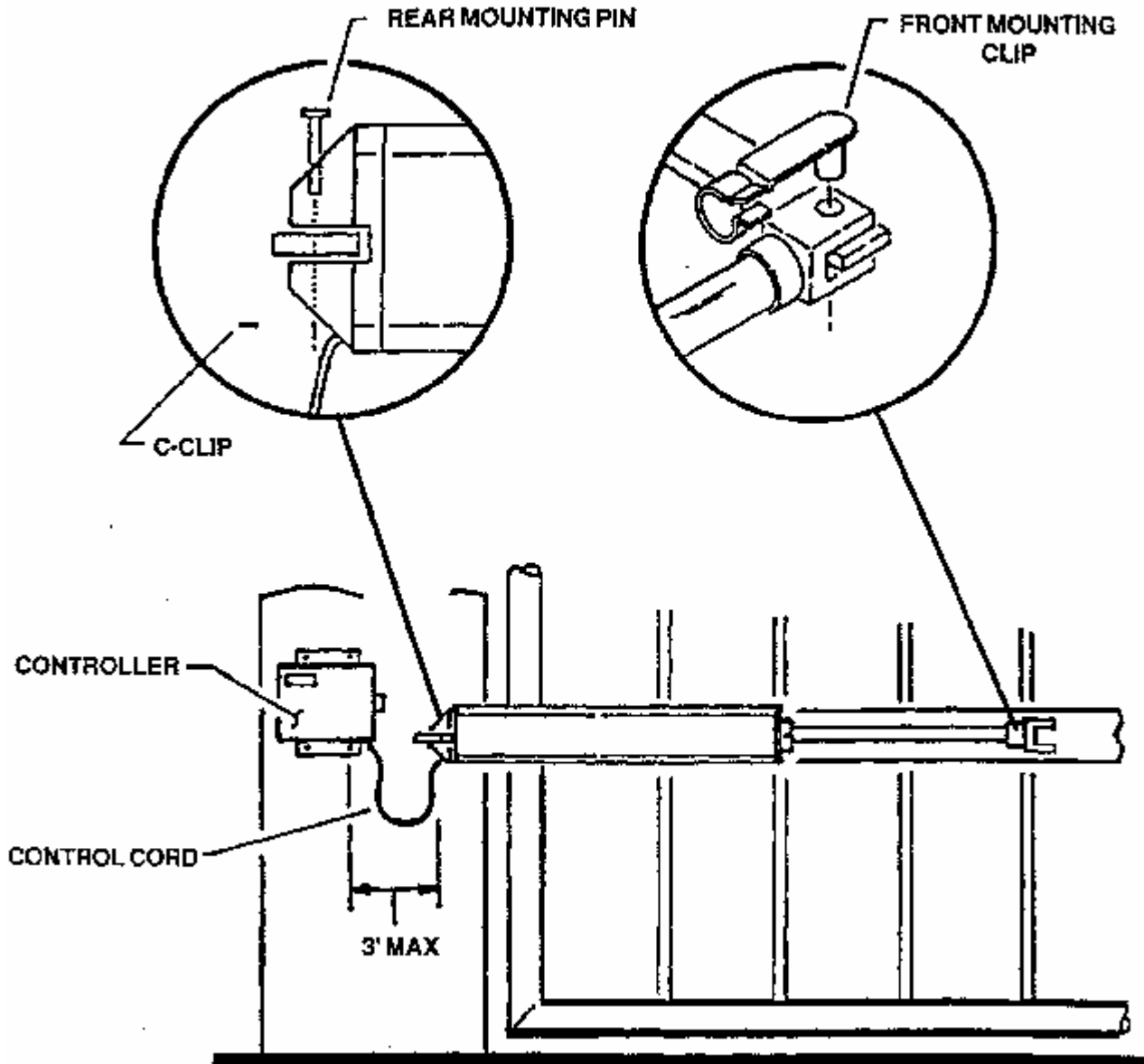

Figure B

## Step 4: Mounting

- A. Manually *open* the gate and attach the unit to the two (2) mounting brackets. (see above)
- B. Manually open and close the gate a few times to ensure that the mounting brackets and gate stops are positioned properly with no interference. (The unit is shipped in the disconnect position to allow for this.)
- C. Mount the controller in a convenient location, within reach of the unit's 4 ft. control cord. Make sure the cord is not stretched taut (it should have a slight amount of slack during the full cycle).
- D. For *Master/Slave Option* - Mount both units. Mount the controller near the "master unit" and the junction box near the "slave unit."



## Step 5 :Primary Voltage Wiring

**⚠ CAUTION:** Make sure power is disconnected at main power supply and at power disconnect switch on operator before continuing.

**Note:** Terminal strips unplug for easy wire connection, make sure you plug them correctly and don't offset the terminal strip in the terminal strip socket.

<p>A. Connect 120 VAC, single phase power, black wire to terminal 10, white wire (neutral) to terminal 9 and ground wire to terminal 11.</p>	<p><b>For Optional Master/ Slave</b> Connect the control cord from the slave unit to the junction box then connect from the junction box to the Power wiring terminal strip, as shown.</p>
<p>B. Connect the control cord from the opener unit to the power terminal strip as shown in the <b>TERMINAL CONNECTIONS TABLE</b> and <b>CONTROL PANEL LAYOUT</b> schematic.</p>	<p><b>⚠</b> All Outdoor 120 VAC connections must be in water-tight conduit as per local building codes. Consult your local building department for your local building code requirements.</p>

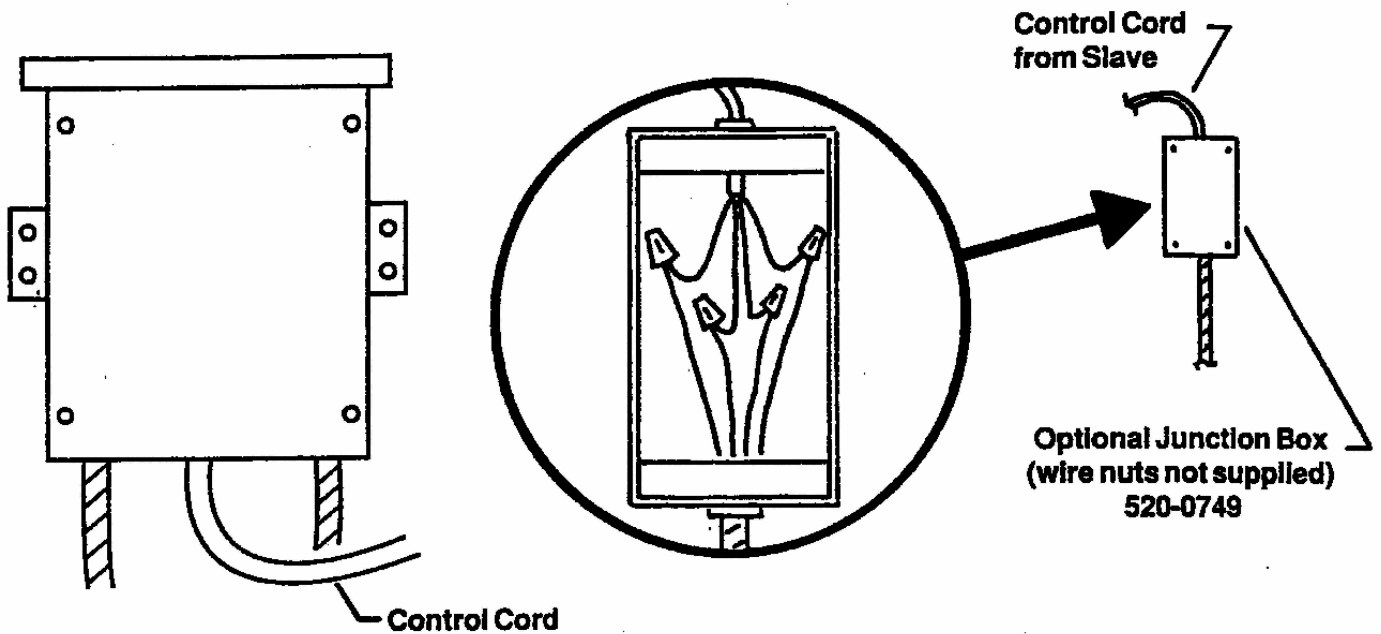

**Conduit Locations May Vary**

## Step 6: Control Wiring

All controls that are to be added must be connected to the control wiring terminal strip as shown CONTROL PANEL LAYOUT AND TERMINAL CONNECTIONS BELOW.

**⚠ PLEASE INSTALL ALL SAFETY DEVICES NECESSARY TO MAKE THIS INSTALLATION AS SAFE AS POSSIBLE.**

### Terminal Strip Connections

Note: Terminal strips unplug for easy wire connection, make sure you plug them correctly and don't offset the terminal strip in the terminal strip socket.

1-	MOT 1A Brown wire from Opener	16-	LIMIT SWITCH input- closes opener-motor 1 (NC)
2-	COM1 Blue wire from Opener	17-	LIMIT SWITCH input- opens opener-motor 1 (NC)
3-	MOT 1C Black wire from Opener	18-	PHOTOCELL input (NC)
4-	MOT 2A Brown wire from 2 <sup>nd</sup> Opener	19-	START input (NO) momentary contact
5-	COM2 Blue wire from 2 <sup>nd</sup> Opener	20-	24VAC output for accessories, (2- photocells & 1 Radio receiver) -8W max.
6-	MOT 2C Brown wire from 2 <sup>nd</sup> Opener	21-	24VAC common 0V for power supply of PHOTOCELLS, ACCESSORIES, & ELECTRIC LOCK
7-	LAMP output	22-	12VAC output for electric lock 15w max
8-	LAMP output	23-	STOP Input (NC)
9-	115V 60H Line Input Neutral ( WHITE WIRE)	24-	PEDESTRIAN GATE START input- motor1 (NO)
10-	115V60H Line input Phase (BLACK WIRE)	25-	COMMON Input for: STOP-START-START PEDESTRIAN GATE
11-	GROUND – Green wire from openers	26-	ANTENNA BRAID GROUND
12-	GROUND – ground wire from line input	27-	ANTENNA CORE WIRE
13-	COMMON for: FA1, FC1, FC2, FA2 & Photocell inputs	28/ 29	RELAY CLEAN CONTACT to: Connect a flashing light with fixed light drawing power from the terminals 7 & 8 (the relay flashes fast during opening and closing) control a warning light to signal gate movement. Connect a 24VAC lamp powered by terminals 20-21 (1 watt max.)
14-	LIMIT SWITCH input- closes opener motor 2 (NC)		
15-	LIMIT SWITCH input- opens opener motor 2 (NC)		

### Installation Notes:

A) This installation is to be supplied by a GFI circuit breaker of 10A ( check with your local building dept. for the proper wiring procedures). The switch must guarantee omni polar separation of the contacts with an opening distance of at least 3 mm.

B) Differentiate and keep the power cables (minimum cross-section 1.5mm<sup>2</sup> ) separate from the signal cables which may be 0.5mm<sup>2</sup>.

C) Make the connections referring to the TERMINAL TABLE above and the following CONTROL PANEL LAYOUT.

D) Be very careful to connect in series all the devices that are connected to the same NC (normally closed) input and in parallel all the devices that share the same NA (normally open) input.

### Connections Terminal Board:

- A. STOP Input terminal 23 can be jumped to terminal 25 COMMON to bypass the safety stop switch for testing, but a safety stop switch is required for the safe operation of this gate!
- B. The large motor capacitor is connected between terminals 1-3 (Motor Opener 1) and 4-6 (Motor Opener 2).

### Trimmer Adjustment:

1. If the system controls a double-gate system with phase shift (V3 turned clockwise), motor opener 1 starts opening two seconds before motor opener, during closing movement delay is set by adjusting trimmer V3.

There are 4 trimmers (V1-V2-V3-V4) on the F4PLUS control unit to adjust the following:

V1	FORCE	Turned clockwise it adjusts the motor torque from 40% to 98% for the first 3 seconds of opener startup.
V2	RUN TIME	Turned clockwise, it adjusts the RUN TIME from 2 to 100 seconds.
V3	PHASE SHIFT TIME	Turned clockwise, it adjusts the delay between the start of the closing movement of motor opener 2 and motor opener 1 (from 0 to 20 seconds). The phase shift during opening is fixed at 2 seconds. With V3 set to minimum the delays are cancelled both during opening and closing (double sliding gate version) and water power boost function is disabled.
V4	PAUSE TIME	Turned clockwise it adjusts the PAUSE TIME from 2 to 100 seconds. Adjusted to minimum, it disables the pause time= STEP-BY-STEP function

### Programming Functions:

Default settings: DIP SWITCHES 1, 2, 3, 9, 10 OFF; DIP SWITCHES 4, 5, 6, 7, 8 ON Trimmer V1 adjusted to maximum, Trimmers V2, V3 and V4 adjusted to half their travel.

DIP 1	ON	When the photocell is intercepted, both during opening and closing, the gate motion is locked until the photocell is freed. Subsequently, there is an opening phase.
DIP 1	OFF	The photocell stops and immediately reverses the motion of the gate during the closing phase, while in the opening phase it has no effect.
DIP 2	ON	Enables multi-user function, i.e. one START command opens the gate, and no other START command are accepted during the opening. During PAUSE, one START command reloads the pause time. During closing, one START command reopens the gate. Re-closing occurs only in automatic mode after the pause time, also when V4 is on minimum.
DIP 2	OFF	Enables the STEP-BY-STEP function (one START command OPENS, a second command STOPS, a third command CLOSES the gate) or STEP-BY-STEP with AUTOMATIC RE-CLOSING depending on how trimmer V4 is positioned: <ul style="list-style-type: none"> <li>• If turned completely counterclockwise= STEP-BY-STEP</li> <li>• If turned clockwise= STEP-BY-STEP with RE-CLOSING i.e. after the pause time it re-closes automatically. To close with the remote control during the pause, two start commands must be given ( the first command sets the gate to stop).</li> </ul>
DIP 3	ON	Enables a POWER BOOSTER function- exercises a brief thrust closing and before opening, facilitating release of the electric lock ( if the limit switches are used, this function is disabled).
DIP 9	ON	The outputs 7-8 of the terminal board are used to control FLASHING LIGHT equipped with its own flashing circuit.
DIP 9	OFF	The outputs of 7-8 of the terminal board become outputs for the COURTESY LIGHT and remain active for 3 minutes after the run time (max. 100 w). In this mode the terminals 28-29 can be used to connect a FLASHING LIGHT without flashing circuit.
DIP 10	ON	Enables PEDESTRIAN GATE OPENING with 2 <sup>nd</sup> key of the remote control. (F4 plus/RR only).

### LIMIT SWITCH CUTOUTS- limit switches not used.

DIP 4	ON	Cuts out limit switch input- opens motor opener 1
DIP 5	ON	Cuts out limit switch input- closes motor opener1
DIP 6	ON	Cuts out limit switch input- opens motor opener 2
DIP 7	ON	Cuts out limit switch input- closes motor opener 2
DIP 8	ON	Cuts out photocell input

**WARNING!! IN THE EVENT OF A SYSTEM WITH ONLY ONE MOTOR OPENER AND USING THE LIMIT SWITCHES, THE DIP SWITCHES 4,5,6, AND 7 MUST ALL BE SET TO OFF, WHILE IF USING ONLY ONE TYPE OF LIMIT SWITCH, E.G. Fa1 and/or Fa2, ENABLE (OFF position ) FOR THE CORRESPONDING DIP SWITCH.**

### Final checks and testing

Before powering the control unit, check the following:

- 1) Check that the dip switches and trimmers have been set properly according to requirements.
- 2) Check the electrical connections; Improper connection may cause damage to the control unit and the operator.

## **Power the devices**

- 3) Check that the 5 red LEDs of the safety devices are on and the yellow LEDs off
- 4) Check that when engaging any limit switches used the corresponding LEDs come on.
- 5) Check that when passing through the beam of the photocells the corresponding LED goes off.
- 6) Check that the motors are locked and ready for operation. Remove any obstacles from the operating range of the gate, then give the START command. Upon the first command, the control unit starts an opening phase; check that the motor rotation direction is correct if not, invert the wires of terminals 1-3 and/or 4-6.
- 7) Fine adjust the trimmers.

## **Radio Module**

### **Code learning:**

When powering the control unit for the first time, check that the red code learning LED is on, indicating that the receiver is ready to learn a remote control (whether DIP SWITCH or Rolling-Code with automatic recognition of the type).

One of the keys of a transmitter can now be pressed (1-2-3 or 4).

When the code has been learned, a command is given to the control unit.

Without pressing the CH1 key again, further remote controls of the same family can be learned, one after the other.

After learning the last remote control, wait for the LED to go off (about 6 seconds) indicating that the system has exited TX learning and is ready to operate normally.

**WARNING:** After learning the first code, the system will accept only that family of codes (if the first is Rolling all the others must be Rolling. If learning is for DIP SWITCH transmitters, only one remote control needs to be learned.

**MEMORY RESET:** If a mistake is made or all the codes need to be deleted, press the CH1 key (the red LED comes on) and hold it pressed down until the LED goes off again. When the key is released, the LED flashes (indicating that the memory is empty) and then comes back on, indicating that the system is ready to learn a new remote control (whether DIP SWITCH or Rolling-Code).

When learning a remote control key, which is positioned on channel 1 (the one which controls full opening of the gate), the system automatically learns the 2nd key of the remote control which, if enabled with DIP10 (ON), controls the PEDESTRIAN GATE START.

### **Remote control learning without accessing the control unit:**

After letting the system learn a remote control in manual mode (by pressing the key S1), self-learning of other remote controls of the same family can be enabled by simultaneously pressing (for 2 seconds) the keys 1 and 2 of the transmitter already learned. Subsequently, when pressing the key of a new remote control it is self learned. Learning has been successful when it moves the gate.

# CONTROL PANEL LAYOUT

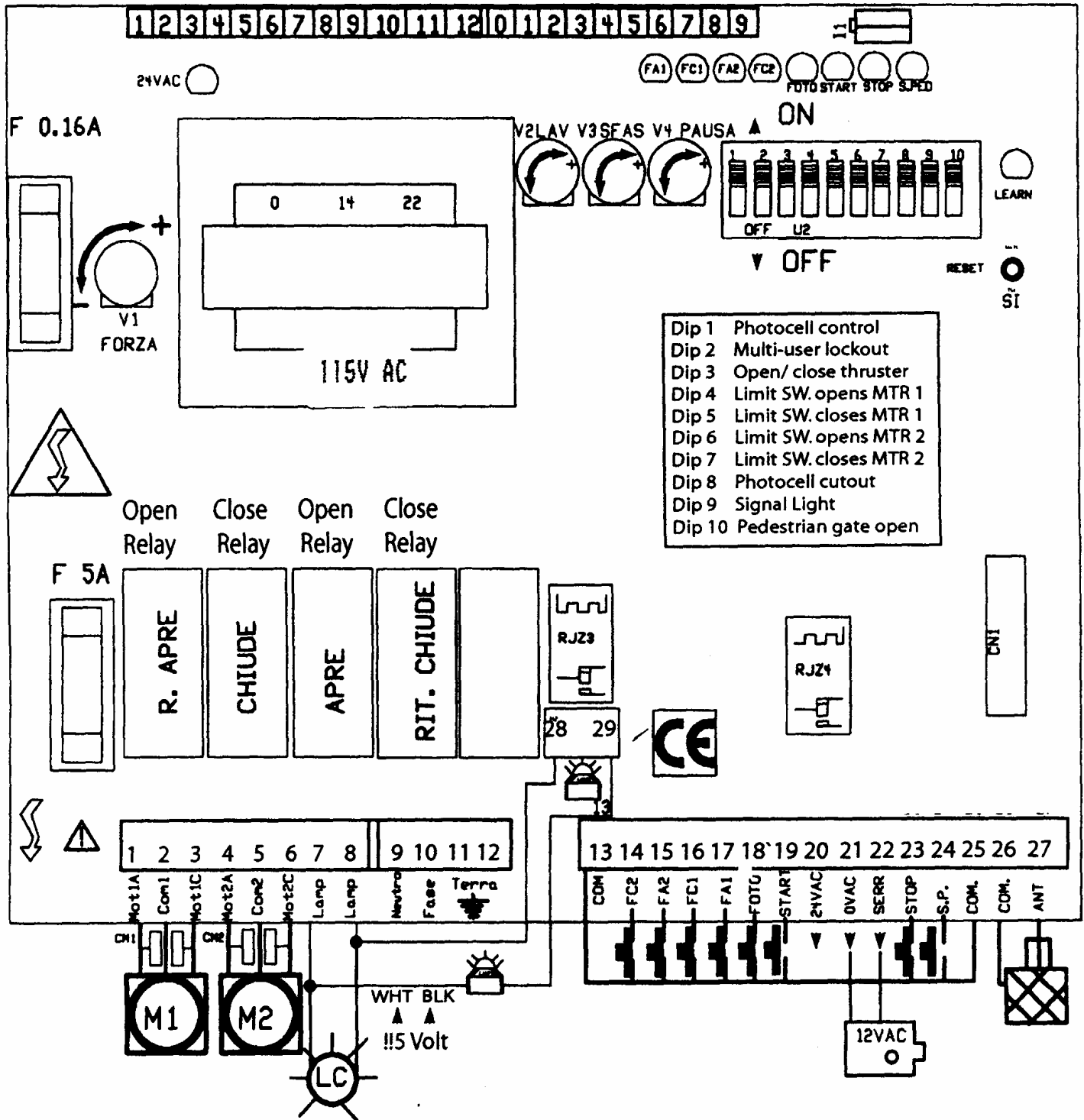

Note: All 5 red LEDs must be on before the operator will run.

## Troubleshooting

Before any installation or maintenance operation, ensure that the power supply has been disconnected.!!

FAULT	POSSIBLE CAUSES and SOLUTIONS
Red 24 Vac LED off	Check that 115Volt power supply and the relevant fuse F1(5A)
The operator does not open or reclose	Check that the red LEDs are on (except the LED of the limit switch active at that moment) and the yellow ones off,
The Flashing Light is on but the gate does not move.	Start has been pressed with the photocells engaged. Check that the photocells are not engaged; once released the gate will start moving.
Red LEDs – FA1-FC1-FA2-FC2-PHOTOCELL off	Check that the relevant inputs and safety switches are connected(FA1-FC1-FA2-FC2-PHOTOCELQ or the relevant DIP SWITCH set to ON. Check the fuse F2 (0.16A).
Red STOP LED off	Check that the STOP input is connected to an NC button or that a jumper has been connected between the terminals 23 and 25 (WARNING: the STOP intervention causes a functional stop and NOT a safety stop).
Yellow LEDs always on	Check that the START and PEDESTRIAN GATE inputs have been connected to (NO) buttons.
After the run time the gate does not reclose	Check that the trimmer V4 (Pause) is not turned completely anticlockwise.
After the motors have stopped, the FLASHING LIGHT connected to terminals 7-8 does not go off.	Check that DIP9 is set to ON If only 2 limit switches are used, the relevant DIP SWITCHES must set to OFF, the other 2 to ON.
When the 2nd key of the remote control is pressed, the pedestrian gate is not activated	Check that DIP10 is set to ON
The gate does not perform a phase shift when it starts	Check that the trimmer V3 (closing delay) is not turned completely counterclockwise.
The transmitter has a small range	Check that the antenna has been positioned properly (braid terminal 26, core terminal 27.if a built-in radio or AU01630N receiver is used) (if an AU01710 plug-in receiver is used, the antenna must be connected to the terminals on the receiver). Check that there are no sources of disturbances in the vicinity which limit the range.
The card does not learn the TX code	Check the maximum number of codes that can be stored (200). Check if remote controls of the same family as the first are being learned: DIP SWITCH or ROLLING. Check that the frequency of the radio control is the same as the receiver.
When key 2 of the TX is pressed, both yellow LEDs come on (START and PEDESTRIAN GATE)	The remote control has been learned by pressing the 2nd key and hence both the 1st channel and the 2nd channel are controlled by key 2. Reset the memory and relearn the transmitters.

### Warnings:

While wiring or inserting the RADIO MODULE, the control unit must not be powered. Use of this control unit must rigorously conform to the reference technical regulations. Installation and/or maintenance must be carried out only by qualified personnel in observance of the FCC regulations. The manufacturer cannot be held responsible for any damage caused by improper and/or irrational use .

Upswung LLC declines all responsibility for any inaccuracies contained in this manual and reserves the right to make modifications – without prior notice.

## Step 7: Hydraulic Adjustments

A. Remove the plastic cover from the unit.

B. Locate the by-pass valve. Using the hex key supplied, re-engage the by-pass valve by turning it clockwise as far as possible.

C. Turn power on at main power supply and at power disconnect switch. The controller may have a 7 second delay from power-up until a signal can be received.

D. With gate open, activate the unit to close. Using a flat blade screwdriver, slowly turn the close pressure valve clockwise until the gate begins to move, then adjust it 1/4 to 1/2 turn more. (Unit is shipped with pressure valves set at minimum.)

NOTE: Since the unit's cycle time has yet to be adjusted, it may shut off too soon or may run longer than desired.

NEVER adjust the open and/or close pressure valves to their maximum setting. Always use the minimum setting required to move the gate. If strong wind loads are a possibility, increase the run time NOT the pressure valves.

E. Locate the open pressure valve. Activate the unit to open and adjust it in the same manner as the close direction.

**IMPORTANT:** The open & close pressure valves must be adjusted properly. They should develop enough force to open and close the gate properly. If the gate meets an obstruction there will be a minimum amount of force applied. Check this by holding the gate when it is closing and opening. For manual operation of the gate, use the hex key and turn the by-pass valve counter-clockwise to disconnect the unit. To reconnect the unit, turn the by-pass valve clockwise.

F. When all the valves have been adjusted, replace the plastic cover.

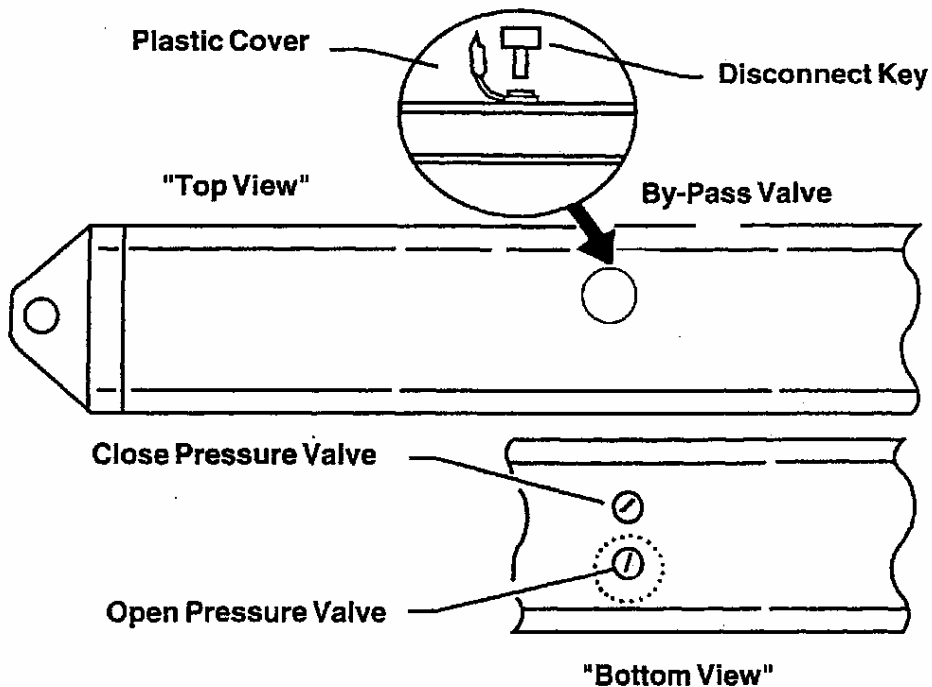

## Step 8 Rod Cover

A. Install the rod cover over the piston rod, as shown. **IMPORTANT: The cover must be installed to keep the piston rod clean and nick-free.**

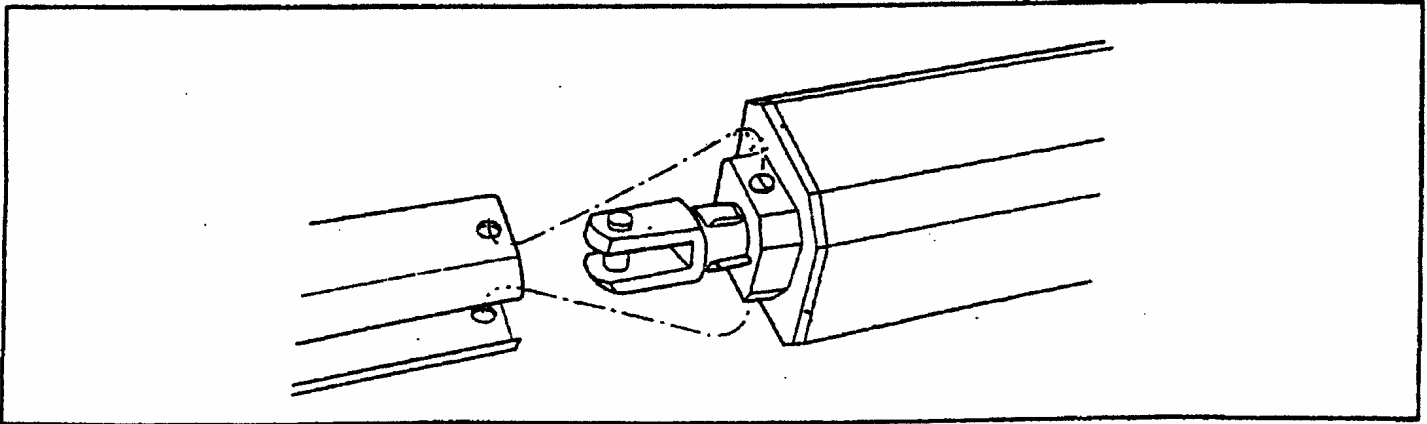

### Swing Gate Operator Model H L410

#### **System Check-Out**

Upswung LLC strongly recommends that at this time you check out the entire system.

1. Make sure the unit fully opens and closes the gate properly.
2. Check all controls that activate the gate to ensure they are working properly.
3. It is extremely important that all safety devices be checked and double checked.
4. Double check the manual operation features and pressure valves of the system. NOTE: If a problem should arise, see Model HL410 Troubleshooting Guide.

And Finally.....

- Install the gate caution signs on both the inside and outside of the gate where they can be easily seen.
- Make sure the unit and controller are free of grease or dirt. Clean, if necessary.
- Clean up the area around the gate.
- Look around for any tools or equipment that may be left.
- Please leave this manual and the troubleshooting guide with the customer.

Let the customer know you've finished installing the unit and review all pertinent information, including safety features and maintenance, with them.

#### **LIMITED ONE-YEAR WARRANTY**

Upswung LLC gate operators are warranted against deficiencies in material and workmanship for a period of one (1) year from date of purchase, providing recommended installation and maintenance procedures are followed. This warranty is in lieu of all other warranties expressed or implied (some states do not allow limitations on how long an implied warranty lasts, so this limitation may not apply to you) and shall be considered void if damage was due to improper installation or use, connection to improper power source, or if damage was caused by fire, flood or lightning. The manufacturer will not be responsible for any labor charges incurred in the removal or replacement of deficient parts.

In case of failure due to deficiencies in material or workmanship during the warranty period, the complete gate operator will be repaired or replaced at the manufacture's option. New or factory rebuilt replacements will be used. Replacement parts are warranted for the remaining portion of the original warrant period. Upswung LLC will pay freight on our return of repaired or replaced items in warranty. For information on how to obtain replacement parts or a replacement operator under terms of this warranty contact Upswung LLC, PO Box 2713, Stateline, NV. 89449

This warranty gives you specific rights, and you may also have other rights which vary from state to state.

## Model HL410-11 Parts List

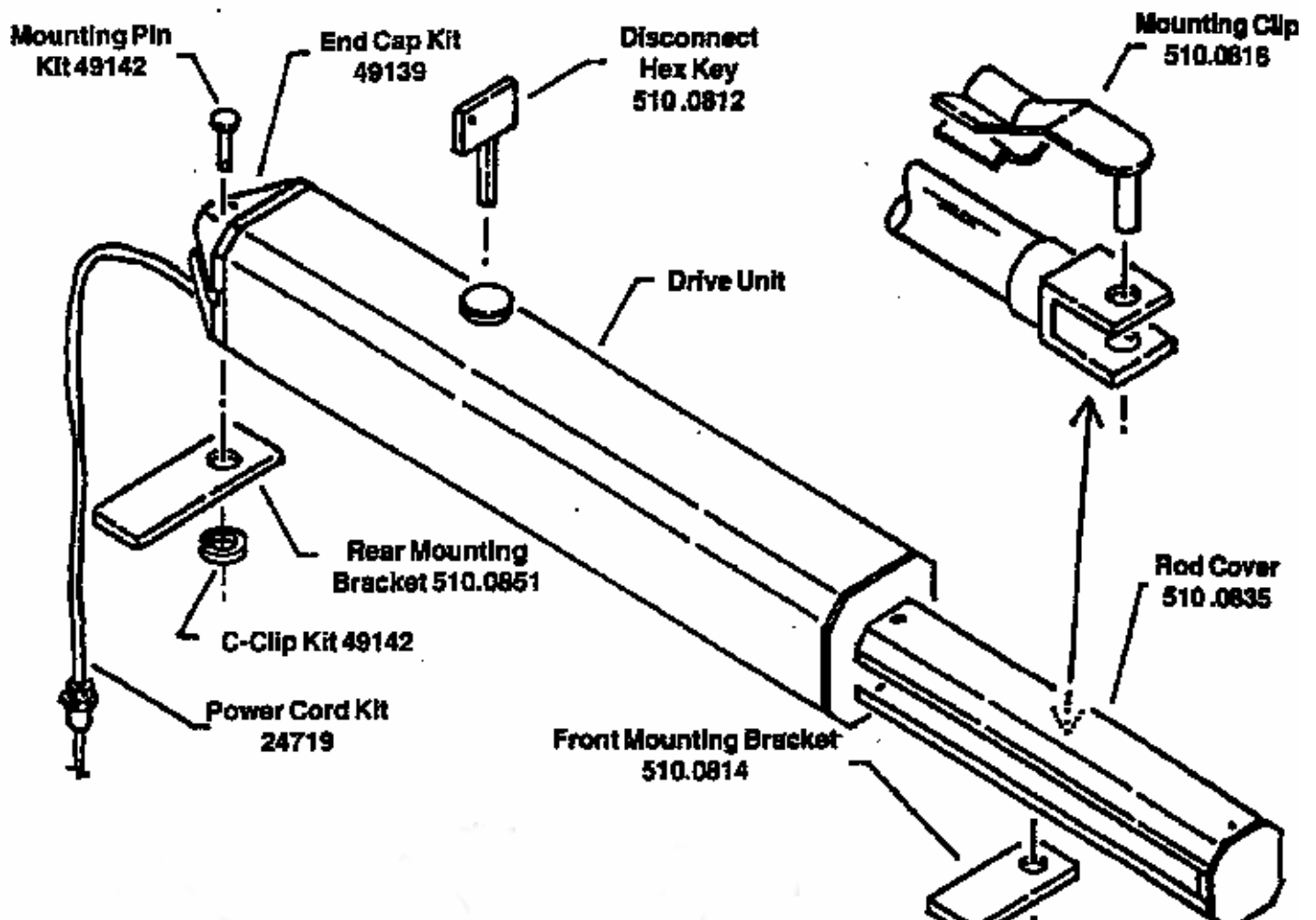

## Required Maintenance Services

	Maintenance Service Required Every-	1-month	6-months	12-months
Gate	Inspect for wear and/or damage	0		C O M P L E T E  C H E C K
Manual Operation	Check & adjust if required		0	
Close Pressure	Check & adjust if required	0		
Open Pressure	Check & adjust if required	0		
Fluid Level	Contact factory		0	
Accessories	Inspect & test		0	
 Safety Devices	Inspect & test	0		

- Inspection and service should be performed anytime a malfunction is observed or suspect.
- High cycle usage will require more frequent service checks.



• ALWAYS DISCONNECT POWER WHEN SERVICING!!

- Use only EXXON Superflo or Dexron ATF (Automatic Transmission Fluid).

Your Professional Upswung dealer is: